

Alkaline Spring-Quality Water From EVERY Faucet In Your Home!



## OWNERS MANUAL & PRODUCT INSTALLATION GUIDE



[www.kingwaterfiltration.com](http://www.kingwaterfiltration.com)



## **About Us**

As the Star of the international hit TV show “TANKED” featured on Animal Planet, and the creator of the King Water Filtration System, **Wayde King** knows a thing or two about water. After more than **thirty years** of designing & building custom aquatic tanks for some of the world’s richest and most famous clientele, Wayde understands the precise filtration techniques required to maintain water purity. Recognizing that today’s widespread environmental hazards and contaminated water supply present serious health concerns for most of the world’s population, Wayde realized the importance of providing safe and pure drinking water worldwide.

The KWF residential water treatment system utilizes natural filtration medias to remove Chlorine, Heavy Metals, and Volatile Organic Compounds commonly found in most municipal water supplies. Wayde’s 30+ years of experience dealing with water allowed him to recognize the serious problems existing due to our contaminated water supply. This crisis led him to design the most technologically advanced, maintenance free, water treatment system available in today’s marketplace. The KWF filtration system not only removes harmful contaminants but will also will reduce harmful scale buildup, extend the life of your plumbing and appliances, and, most importantly, provide pure alkaline quality drinking water for the needs of you and your family from every faucet in your home.

## **King Water Filtration System Benefits and Features:**

The KWF whole home water treatment system is a 3 stage organic filtration system that uses redox bacteriostatic and activated carbon media filtration to remove chlorine, harmful chemicals and metals from your household water supply.

The KWF system is managed by an automatic control valve that is programmed to backwash and cleans the system out automatically and has been preset at our factory, however these settings can be adjusted to your specific needs from the electronic control module timer. It will retain its' programming evening in a power outage as it has battery backup.

Our multi-polarity anti-scale magnet will protect your plumbing and appliances from scale build up and corrosion. As a matter of fact, it will not only prevent scale build up, but it will also help dissolve existing scale formation. Magnetic descaling works by converting the Calcium Bi-Carbonate ("Sticky Calcium") to Calcium Aragonite ("Non-Sticky Calcium"). Calcium Aragonite is water-soluble and is molecularly attracted to it, rather than being attracted to your plumbing fixtures and appliances. Calcium Aragonite also provides a natural alkaline balance to your drinking water assisting to better hydrate your body.

**\*\*\*When testing for your water hardness, the healthy minerals will purposely remain thus you will still have what is commonly called "hard" water in most areas. The KWF water treatment system does not remove these healthy minerals, but rather it treats these minerals so as that they are in a water soluble state giving you scale free water that is easier to clean with and will lengthen the life of your plumbing and fixtures, but most importantly it will provide healthy, mineral rich, spring quality, alkaline water for your household.\*\*\***

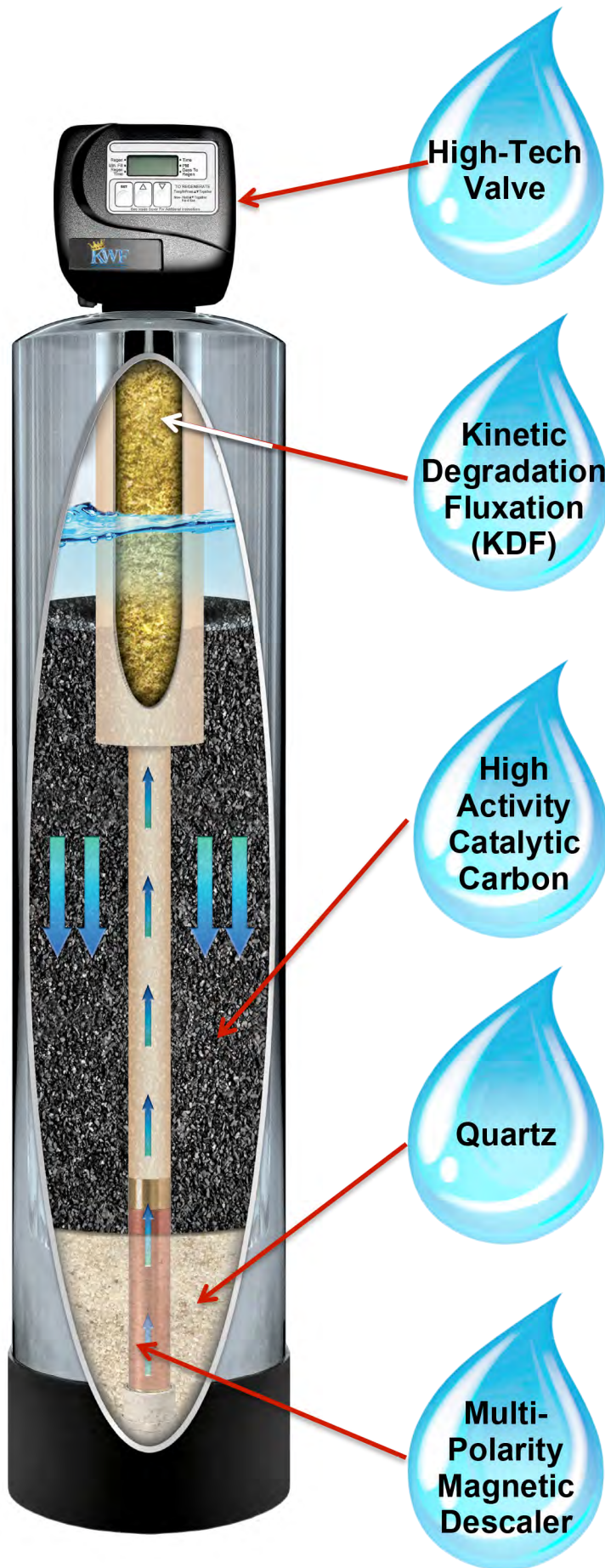

**High-Tech Valve**

- Automatic Timer
- Fully programmable
- No pressure loss
- Battery backup

**Kinetic Degradation Fluxation (KDF)**

- Removes Chlorine
- Removes Iron
- Removes Heavy Metals
- Removes Microorganisms
- Natural Bacteriostatic Prevents Bacterial Growth

**High Activity Catalytic Carbon**

- Removes Chlorine, Chloramines, Hydrogen Sulfide, Volatile Organic Compounds,
- Catalytic Activity
- Lasts up to 6x Longer
- Higher pH Balance

**Quartz**

- Provides excellent media bed for unrestricted water flow
- Removes suspended particles and sedimentation
- Neutralizes tastes and odors

**Multi-Polarity Magnetic Descaler**

- Energy Efficient
- Converts Calcium Bicarbonate to Naturally Occurring Water Soluble Calcium Aragonite
- Environmentally Friendly
- Breaks down existing scale and prevents future scale buildup

## **A Water Filtration System That SAVES MONEY and the ENVIRONMENT!!!**

- ✓ **Save approximately \$450** per year on wasted water vs. a salt water softener
- ✓ **Save approximately \$100** per year on Salt vs. a salt water softener
- ✓ **Save approximately \$100** per year on reverse osmosis wasted water
- ✓ **Save approximately \$150** per year on reverse osmosis filter changes
- ✓ **Save approximately \$250** per year on bottled water
- ✓ **Save approximately \$900** per year on bottled water delivery service
- ✓ **Save approximately \$100** per year on plumbing and fixture maintenance

\*\*\*That's an approximate ***SAVINGS of \$1950.00*** per year vs. traditional household water treatment methods\*\*\*

## **System Benefits:**

- + Produces Great Tasting spring quality alkaline water from every faucet in your home.***
- + Maintains Healthy Minerals***
- + Removes Chlorine, Heavy Metals, and Volatile Organic Compounds***
- + 100% American Made by American Workers***
- + Maintenance Free Operation***
- + Controls Hard Water Scale***
- + Increase the life of your appliances and fixtures***
- + Industry Leading 20 Year Warranty***
- + Eliminate the need for bottled water***
- + Eliminate the need for reverse osmosis drinking water systems***
- + Improve the taste and quality of food and drinks***
- + Softer and Healthier Hair and Skin***
- + No Salt and No Potassium***
- + Clothes and linens will last longer than using municipally treated water***

## **Measuring System Effectiveness:**

- Pure refreshing taste
- Your hair will feel softer and less dry
- Your skin will feel softer and less dry
- Soaps will lather more easily
- Less detergent in dishwasher when compared to municipal water
- Less detergent needed for washing clothes compared to municipal water
- Less spotting on dishes when compared to municipal water
- Clothes will be whiter and/or more vibrant in color due to the removal of chlorine
- The screens in your aerators on faucets and shower heads will start to remove existing scale

## **Evaporative Spotting:**

Being that the KWF does not remove any nutrients from the water it may cause minimal spotting if accumulated water is left to evaporate on surfaces such as shower doors or countertops. Our system process will cause the minerals to lose their ability to adhere to most surfaces allowing any spotting to wipe off easier than regular hard water or sodium spots caused by water softeners. Not to be confused with a traditional ion-exchange water softener that requires regular maintenance and the reoccurring high cost of salt or potassium, our maintenance free system works differently. It does not remove the minerals (because minerals promote your good health). Instead it changes the minerals to water-soluble form that won't stick to your plumbing or cause hard water staining.

## **INSTALLATION INSTRUCTIONS:**

1. Connect Inlet/Outlet of system to the water loop or main line to the house. Make sure to identify correctly the Inlet and Outlet of system with the waterline.
2. Plumb system drain line.
3. Plug in system and set the time. (See operations manual)
4. Turn on the water to the system, make sure the system is in the "Bypass" position. (Figure 2)
5. Check for water leaks, repair if necessary.
6. Regenerate the system.
7. Slowly open the inlet side of the bypass and allow water to fill the tank. (Figure 4)
8. When water is flowing to drain, close the bypass inlet valve and let the system "soak" the media for 2 hours. (Figure 2)
9. Regenerate the system again and slowly open the inlet valve, when water is flowing to drain slowly open the outlet valve. (Figure 1)
10. Let the system completely finish its backwash cycle. (It will do it automatically)
11. Start enjoying your new King Water Filtration System.

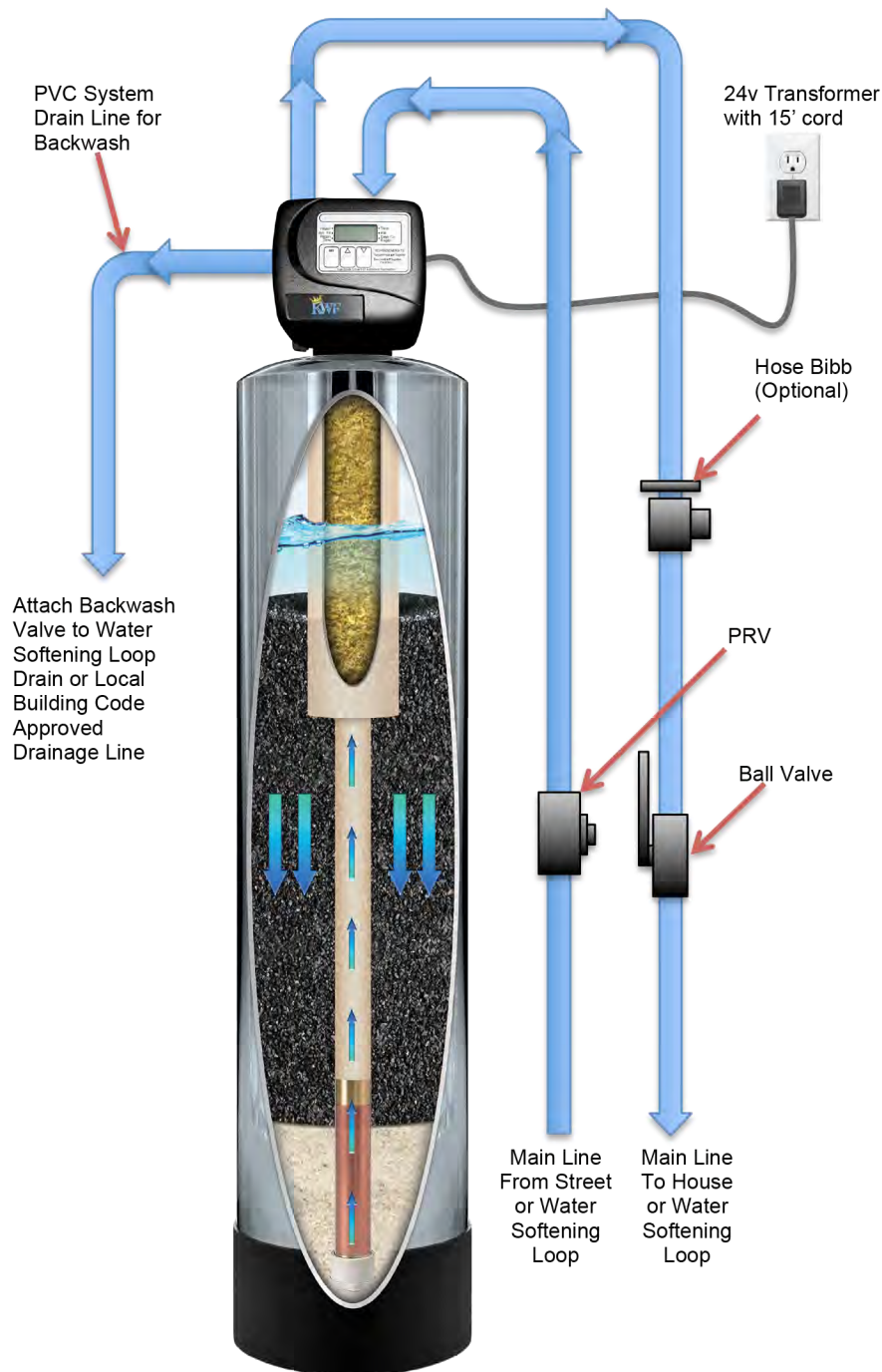

***\*\*\*Installation should only be done by an authorized professional that is familiar with local building codes\*\*\****



Figure 1

### NORMAL OPERATION

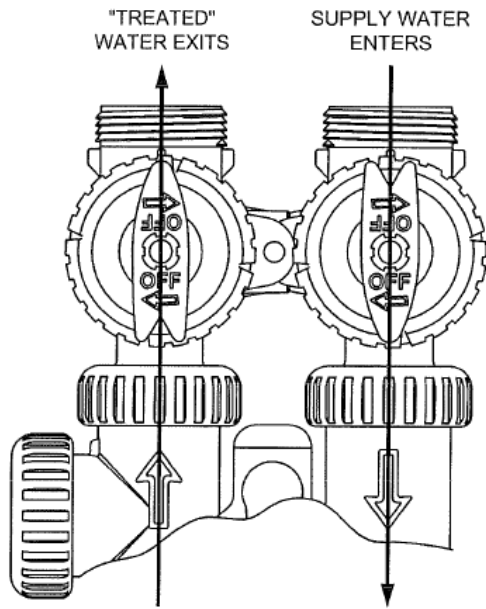

Figure 2

### BYPASS OPERATION

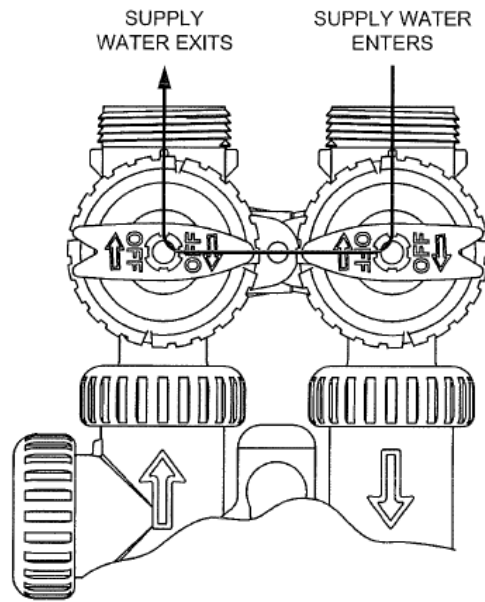

Figure 3

### DIAGNOSTIC MODE

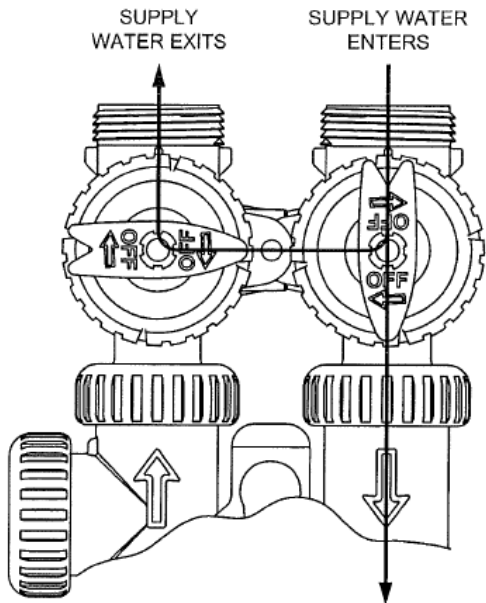
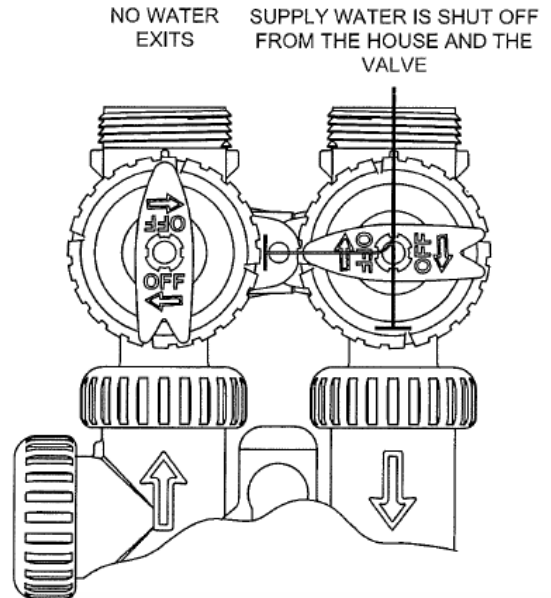

Figure 4

### SHUT OFF MODE



## Disclaimer

**WARNING: Do not use with water that is microbiologically unsafe or of unknown origins without adequate disinfection methods. To be used for treatment of municipal water only. Well water applications require a water analysis be done by an authorized testing facility.**

# Warranty Information

**Pure Water Technologies LLC.  
Non-prorated/Non-Transferable\*  
Limited 20 Year Warranty**

### **Warranty applies to original purchaser of the system**

The manufacturing of King Water Filtration products utilize the highest standards of quality assurance, engineering expertise, and premium materials. Each King Water Filtration system is certified and has undergone gone an extensive final inspection before leaving the factory.

Pure Water Technologies LLC guarantees the tank and valves to be free of defects for a period of 20 years from the date of purchase or 1,250,000 gallons of water usage whichever occurs first, provided that failure does not result from non-municipal water, fire damage, freezing, any evidence of tampering or other acts that are beyond our control. There will be no charge for parts to replace any portion of the system found to be defective during the term of the specified warranty period. Any replacement part deemed to be covered under this warranty will be exchanged for the same or equivalent replacement part or device at no charge to the original purchaser. Customer must provide proof of purchase for any warranty claims. Pure Water Technologies LLC shall not be liable for freight, and/or service charges, if any. Customer will be responsible for shipping charges of defective parts. Media warranty does NOT apply to private well installations, or non municipal water treatment. This warranty does not cover systems that are not set up to backwash, or systems that have manually had their factory backwashing cycle adjusted beyond the recommended time frame.

### **This Warranty will only be honored under the following conditions:**

Equipment is limited to; Water supplied to the King Water Filtration system is not to exceed 85 PSI, and water temperatures not to exceed 110 degrees F. or under 32 degrees F.

Defective parts are subject to inspection by either Pure Water Technologies LLC or an authorized representative.

We reserve the right to discontinue or change any of our products, and or terms, at any time and without notice or liability. If, for any reason, products of the type originally installed are no longer available from us at the time you make a warranty claim, we will substitute another product manufactured and determined by Pure Water Technologies LLC to be of comparable quality and price.

WE EXCLUDE AND ARE NOT RESPONSIBLE FOR ANY CONSEQUENTIAL OR INCIDENTAL DAMAGES ARISING OUT OF ANY BREACH OF THIS EXPRESSED WARRANTY AS IT RELATES TO OUR PRODUCTS. SOME STATES DO NOT ALLOW THE EXCLUSION OR LIMITATION OF SUCH DAMAGES, SO THE ABOVE LIMITATION OR EXCLUSION MAY NOT APPLY TO YOU. THIS WARRANTY IS IN LIEU OF ALL OTHER WARRANTIES, EXPRESSED OR IMPLIED, INCLUDING BUT NOT LIMITED TO IMPLIED WARRANTIES OF MERCHANTABILITY AND FITNESS FOR A PARTICULAR PURPOSE.

WE ARE NOT LIABLE FOR ANY CONSEQUENTIAL DAMAGES OR INCIDENTAL DAMAGES caused by any defect in any of our products covered under any expressed, written, oral or implied warranty. Your EXCLUSIVE REMEDY for any such defect is the repair or replacement of our product.

HOW YOU SUBMIT A WARRANTY CLAIM: You must submit your claim in writing to us within the warranty period and 5 business days period of time after the defect is discovered. To initiate a claim, you should contact our warranty services department at 5502 S. Fort Apache #100 Las Vegas, NV 89148. Please provide the following information: model number, serial number, and date and proof of purchase. For questions email [CustomerService@KingWaterFiltration.com](mailto:CustomerService@KingWaterFiltration.com).